

Installation instruction K Neutral

No time for manuals? No problem, this will only take a few minutes of your time to read it and the installation of your new K Neutral module is done fast and easy :-)

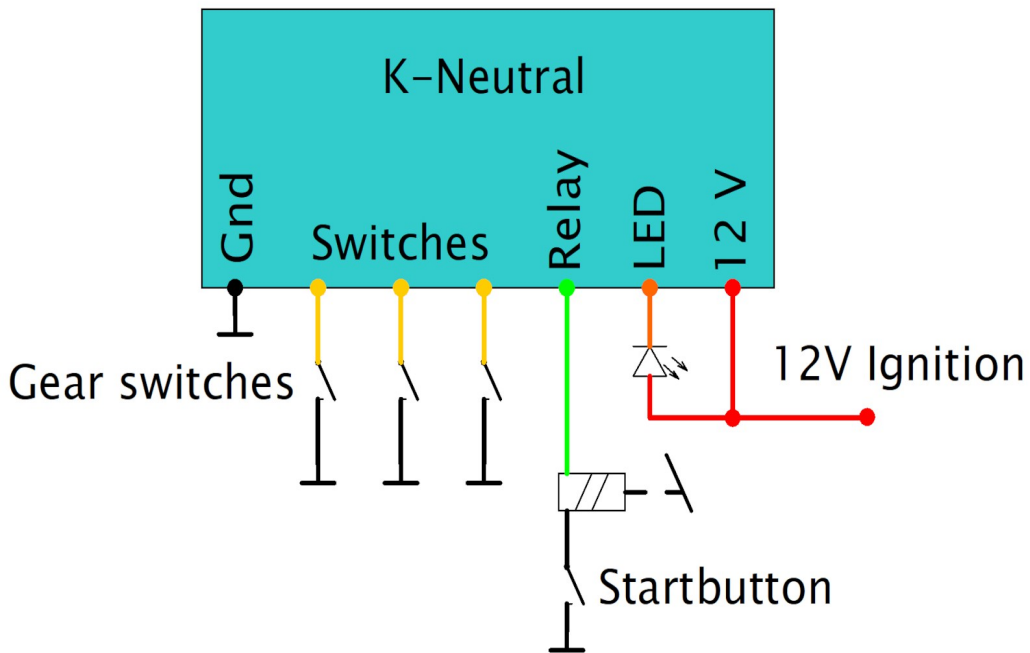

Colour	Description
Yellow (3 x)	These are the connections to the 3 gear box switches. The module indicates the neutral position of the gearbox when all switches are closed to ground. However, the module just looks if the three switches are closed, no matter in what range the cables are connected to the gear box switches.
Green	Output to the starter relay. The module switches 12 Volts to this output when the 3 gearbox switches are closed and enable the starter relay.
Orange	Output to a neutral led. This output is switched to ground if the gear box is in neutral position. This works for almost every aftermarket dashboard or speedo. This output is made for led use. Don't connect it to an old indicator bulb. This will not work.
Red	+ 12 Volts after the ignition switch. Please wire a 1 Ampere fuse between the ignition switch and the module.
Black	Ground

The K Neutral module should be installed by professional well trained engineers. Please check your local regulations regarding the traffic light rules in your country before use the module in your bike. Please be aware that we are not responsible for any hazards, damages or disadvantages due to the use of this device. We also declare that the module is conform to the CE and ROHS regulations for the European market. We tried to keep the functions of the module and this manual as simple as possible. However, please don't hesitate to contact us at info@elektronikbox.de if you have any questions during the installation.

We wish you to have a lot of fun with your new K-Neutral in your bike and of course always Ride Safe!