

# Installation manual for the D-Box from 12.2022

No time for manuals? No problem, this will take only 3 minutes of your time to read it and you will have more fun while the installation of your new D-Box.

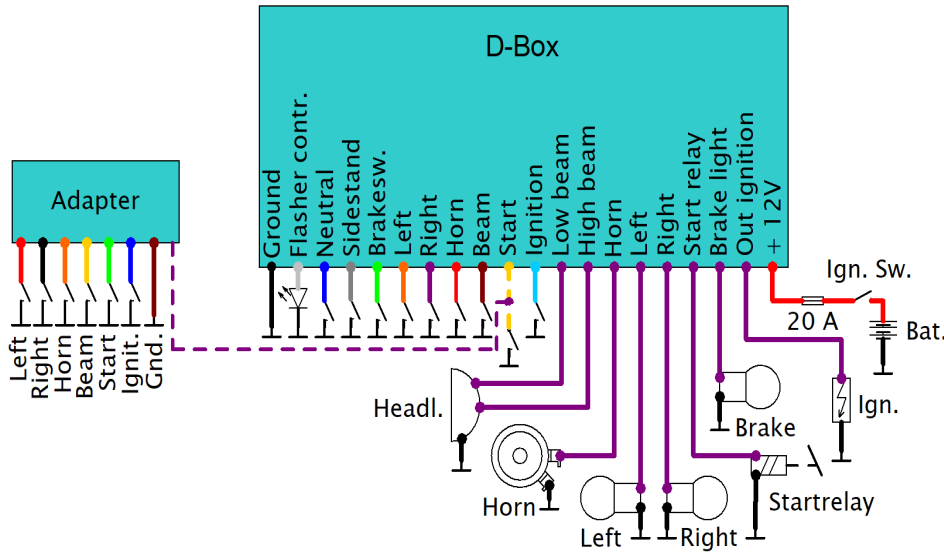

**Push button or switch input for the direction indicators (purple and orange):** You can use these inputs for push buttons or a switch what will connect the input to ground / chassis when pressed. An closed contact will start the indicator. These inputs can also be use for the **2 – Button Mode (Option 6)**.

You can connect the **white cable** to the flasher control led in your speedo.

The **dark blue and the grey** cables are connected to the sidestand switch if implemented and to the neutral switch. It's only necessary if you have activated the security functions in the box (Option 5).

**An emergency flasher function** is active by pressing both direction buttons. This function is only enabled in the "button mode" for the flasher section.

**Push button for the horn function (thin red):** The horn work when this input is connected to ground via the button.

**Button or Switch input for the headlight (brown):** The headlight will toggle between high - and low beam when the button is pressed and the input cable is connected to ground.

**Button input for the start relay (yellow):** The relay output switch the 12 volt for the starter relay when the button is pressed and the input cable is connected to ground. The D-Box recognizes if you connect the violet cable of a handlebar adapter to this cable and switches to button mode in this case. In 5 button mode is this also the control input for the ignition. A short press (below 0,3 sec) on the button switch the ignition and a longer press of more than 0,3 sec. will activate the starter circuit. **The optional available handle bar adapter is not usable for the 5 button mode.**

**Input for engine stop (light blue):** This is the connection for the engine stop function. A press on the button will switch on or off the 12 Volt power from the D-Box to the ignition. The ignition is on if this input is connected to ground and you have choosed the "Engine Off Switch" option.

**Brake light switch (green):** You can connect your brake light switch(es) to this cable and control your brake light or rear light with this input.

**Ground (black):** Just connect the black cable direct to the minus pole of the battery.

**Output low beam:** This is the 12 Volt output for the low beam headlight. However, the light can be switched off when pressing the "start" button in order to have enough energy for the starter (further infos at page 2, "setup").

**Output high beam:** This is the 12 Volt output for the high beam bulb.

**Output horn:** This is the 12 Volt output to the horn, what is active by a button press. **Be careful, this output can control modern horns with maximum 3 Ampere. Every current above this value might destroy this output.**

**Flasher outputs left and right:** These are the 12 Volt power outputs to the turn signals. However, the flasher frequency is independent of the load. So, problems with led flashers are a matter of the past.

**Output start relay:** This output is connected to the **start relay and not** direct to the starter. This output can supply maximum 3 Ampere.

**Output brake light / rear light:** This output is connected to the brake light. You can use this cable for the rear light as well if you switch on the mode option 5 (see page 2).

**12 V Output to ignition:** This output is connected with the ignition. A press on the stop button will switch on or off the ignition.

**+ 12 Volt input from ignition lock (big red cable):** This is the 12 volt power input for the box and the power outputs. The outputs of the box are self resettable in the case of a short circuit. However, the temperatures in the case of a short circuit will reach about 120 degree C what might result in small flaws in the plastic housing and a possible loose of the water protection.

**Adjustment of the different functions:**

The D - Box can be use for the most circumstances without any modification on the box. However, you can easily change some functions in the box without to be a software specialist. Just press the **"left" button and press the brake** while switching on the ignition switch and you are in the "setup mode" after removing the finger from the „left“ button. An one time emergency flash will indicate the "Mode 1". You decide with this mode if you would like to enable the auto off function of the indicators. Just feel free to press the "left" button if you like to use the auto off function of the indicators. Alternatively you can switch off this function by pressing the "right" button and you will come immediately to "Mode 2" what is indicated with 2 flashes of the direction lamps. Feel free to continue to make your personal settings for your bike. All settings are stored in the box after maximum 10 times pressing the "left" or "right" button. Your done! ...it's that simple... The D - Box will keep your settings after a power off. However, you can change the settings at every time you want. The following options are possible:

Number of flashes	Mode	Left flasher button	Right flasher button	Description
1 x	Flasher auto off	Active	Off	The fdirection indicators switch off after 40 flashes.
2 x	Brake light flasher	On	Off	The brake light flashes 3 times before continous on when activated
3 x	Marker Light	On	Off	The direction indicators are continous on when not activated.
4 x	Sidestand - and Neutralswitch option	On	Off	Security option for ignition and starter.
5 x	Harley D. Mode	On	Off	The box work with the TSM / TSSM module if installed in a Harley Davidson
6 x	2 Button mode	Active	Off	You can control the complete box with only 2 push buttons.
7 x	5 Button mode	Active	Off	You can switch the starter and the ignition with one button.
8 x	Engine off switch or button	Switch	Push button	You can control the box with the original switch of your bike or with a push button.
9 x	Flasher control	Permanent switch	Push button	The flasher can be controlled by a push button or by a switch
10 x	Headlight control	Permanent switch	Push button	The box can switch the headlight with the original switch or with a push button.

For **Harley Davidson bikes** you can use the D-Box in combination with the TSM/TSSM module if you wire the left and right output of the D-Box to the button inputs of the TSM/TSSM module (Usually violet / white and brown / white) .

The 2 button mode is easy to use without the need to learn button combinations:

- One short press on the left button: Flasher left on or off.
- One short press on the right button: Flasher right on or off.
- One short press simultaneously on both buttons: Emergency flasher.
- Two short presses on the left button: Toggle between low and high beam.
- Two short presses on the right button: Toggle between Ignition on or off.
- One long press on the left button (> 0,3 sec): Horn
- One long press on the right button (> 0,3 sec): Starter

**Installation:**

The power outputs can work with currents between 3 and 6 Ampere for each output. The maximum current of the D - Box is 20 Ampere due to the small size of the box. The cables to the buttons should be more than 10 cm away from the ignition and spark plug cables (if possible) in order to prevent the box against emv disturbances. Otherwise the D - Box might can do some "funny" unwanted functions like changing the light, switching on the flashers, etc. It's also a good idea to use shielded cables to the push buttons if available.

The D - Box was developed for an implemenation in show bikes and racing bikes. It should be installed by professional well trained engineers only. Please check your local regulations regarding the traffic light rules in your country before of the use of the D - Box in your bike. Please be aware that we are not responsible for any hazards, damages or disadvantages due to the use of the electronicbox. The electronicbox devices are registered under the number DE54933725 WEEE as B2C device. We also declare that the D - Box is conform to the CE and ROHS regulations for the European market.

We tried to keep the functions of the D - Box and this manual as simple as possible. If you have any questions while the installation please don't hesitate to contact us at: [info@elektronikbox.de](mailto:info@elektronikbox.de)

**We wish you to have a lot of fun with your new D - Box in your bike and of course always a safely trip!**