

Installation instruction Speedlimiter

No time for manuals? No problem, this will only take a few minutes of your time to read it and the installation of your new Speedlimiter is done fast and easy :-)

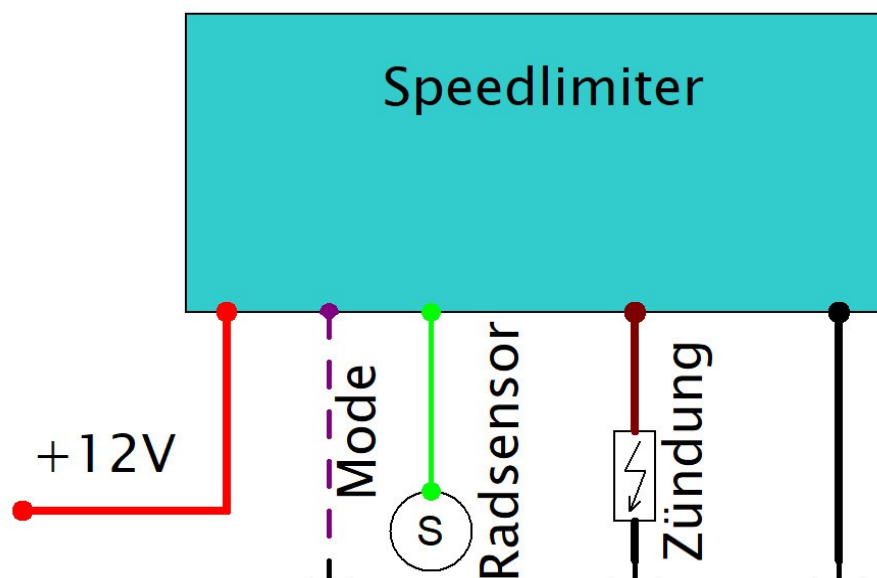

Color	Description
Violet	Setup input for the programming of the maximum speed. Connect this cable to ground and bring your bike to the maximum speed what your bike should ride. Unconnect the green cable from ground when your bike have reach the required maximum speed. The maximum speed is stored in the module in the moment when you remove the cable from ground. By the way you can change the adjustment of the maximum speed at any time you want by wiring the green cable to ground.
Brown	This cable is connected to the 12 Volt power input of the ignition module. The ignition is switched off if your bike exceed the maximum adjusted speed and it switches on again if the speed is below of the adjusted speed.
Green	This cable is wired to the speed sensor of your bike.
Red (thick)	+ 12 Power
Black	Ground

Note:

The violet program cable can be cut or should be insulated after the programming. The output can control ignitions up to 60 Watt.

The Speedlimiter should be installed by professional well trained engineers. Please check your local regulations regarding the traffic light rules in your country before use the module in your bike. Please be aware that we are not responsible for any hazards, damages or disadvantages due to the use of this device. We also declare that the module is conform to the CE and ROHS regulations for the European market.

We tried to keep the functions of the Speedlimiter and this manual as simple as possible. However, please don't hesitate to contact us at info@elektronikbox.de if you have any questions during the installation.

We wish you to have a lot of fun with your new Speedlimiter in your bike and of course always Ride Safe!