

Installation instruction Multi Flash Minus

No time for manuals? No problem, this will only take a few minutes of your time to read it and the installation of your new Multi Flash Minus is done fast and easy :-)

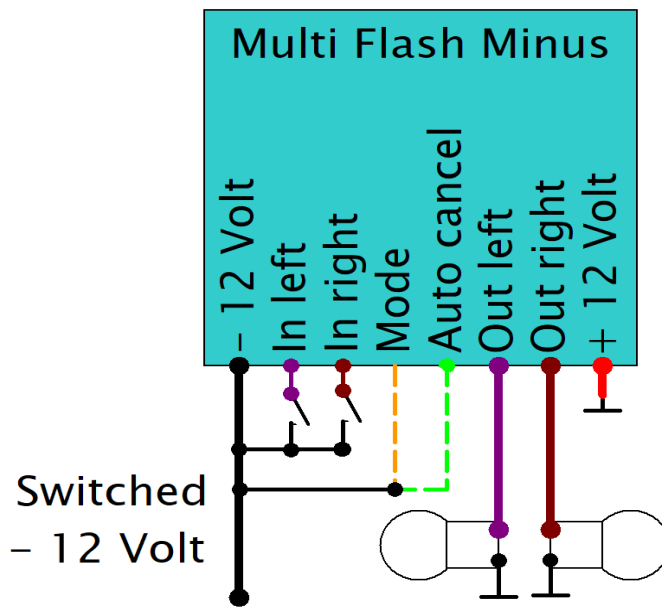

Color	Description
Violet (thin)	Input for the left flasher switch or button. Just connect it to your button and wire the other button cable to plus 12 Volt. A press on the button will switch on or off the flashing function.
Brown (thin)	Input for the right flasher switch or button. Just connect it to your button and wire the other button cable to plus 12 Volt. By the way a simultan press on both buttons activate an emergency flasher function. In the switch mode the emergency flasher function is activated by a fast switching between left and right.
Green	Auto Cancel function. In the button mode the flashers switch off after 4 times if you press the button below 0,5 seconds. The flashers switch off after 40 times if you press and hold the button for more than 0,5 second. In the switch mode the indicators flash 40 times if the switch is moved to one side. You can diable the Auto Cancel function if you wire this cable to ground.
Yellow	If the cable is wired to ground then the module works with momentars buttons. A not connected cable result in the switch mode where the indicators are active as long as the switch is moved to one side.
Red	+ 12 Power
Violet (thick)	Output left flasher
Brown (thick)	Outpur right flasher
Black	Ground

Note:

The outputs can control all kind of 12 Volt led flashers and "traditional" halogen bulbs up to 24 Watt per side. **The outputs are not short circuit protected. Please note that an installation with a very short distance to the ignition might result sometimes in "funny" unwanted functions of the Multi Flash Minus due to electrostatic disturbances.**

The Multi Flash Minus should be installed by professional well trained engineers. Please check your local regulations regarding the traffic light rules in your country before use the Multi Flasher Minus in your bike. Please be aware that we are not responsible for any hazards, damages or disadvantages due to the use of this device. We also declare that the Multi Flash Minus is conform to the CE and ROHS regulations for the European market.

We tried to keep the functions of the Multi Flash Minus and this manual as simple as possible.

However, please don't hesitate to contact us at info@elektronikbox.de if you have any questions during the installation. **We wish you to have a lot of fun with your new Multi Flash Minus in your bike and of course always Ride Safe!**