

Installation manual of the Rear Light US

Almost every bike that runs in the US has a brake light / indicator combination meaning that 2 lamps work as brake light and as direction indicator as well. This can make the conversion of an imported bike from the EU a bit tricky and cost intensive due to wiring and workshop time. The Rear Light US is a microcontroller based solution that merge the two signals to the original flashers and brake light in two separate outputs for brake light / rear light and indicators.

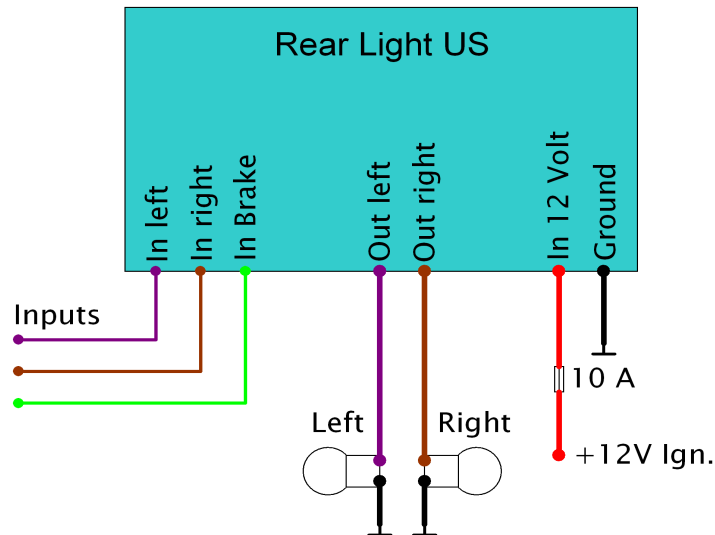

Connection:

+ 12 Volt: This cable is wired to a switched 12 Volt source, like tag light or rear light of your bike.

Gnd: Be connected to the chassis or minus of the harness

In Left This is the connection to the original left indicator that come from the flasher relay and is wired now to the Rear Light US

In Right: This is the connection to the original right indicator, what is wired now to the Rear Light US

In Brake: This is the 12 Volt brake light cable, what comes from the brake switch and goes to the original brake light.

The outputs are short circuit protected if currents above 10 ampere will present. However, we suggest to wire a small fuse in the + 12 Volt main line if you are not sure if the cables from the original control box of your bike to the tag light or rear light can survive short circuits above 10 Ampere.

The Rear Light US was developed for an implementation in show bikes and racing bikes. It should be installed by professional well trained engineers only. Please check your local regulations regarding the traffic light rules in your country before of the use of the Rear Light US in your bike. Please be aware that we are not responsible for any hazards, damages or disadvantages due to the use of the electronicbox. The electronicbox devices are registered under the number DE54933725 WEEE as B2C device. We also declare that the Rear Light US is conform to the CE and ROHS regulations for the European market.

We tried to keep the functions of the Rear Light US and this manual as simple as possible. If you have any questions while the installation please don't hesitate to contact us at: sales@zodiac.nl

However, we wish you a lot of fun with your new Rear Light US and of course always a save trip!