

Installation manual of the Minimal Indicator

The minimal indicator is a small microcontroller module and a 3 color led. The controller drives the different colors of the led and allows to indicate all necessary functions of your bike with just one led. Even 2 or 3 events at the same time can be indicated easily. The small dimensions of the module allows the implementation in the head light or even in the handle bar. With this module you can clean up your dashboard for a much cooler look. You can indicate the following functions with one led.

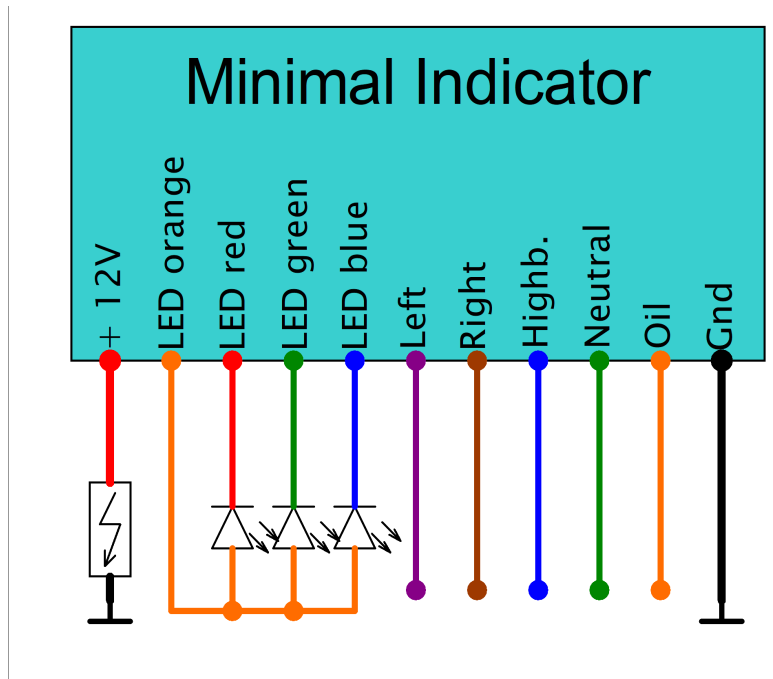

Connection:

Red, + 12 Volt: This cable is wired to a switched 12 Volt source.

Black, gnd: Be connected to the chassis or minus of the harness

Violet, in left This is the connection to the left indicator

Brown, in right: This is the connection to the right indicator.

Blue, in beam: This is the 12 Volt high beam cable, what is connected to the high beam.

Green, in neutral: This cable is wired to the neutral switch.

Orange, in oil pressure.: This cable is wired to the oil pressure switch.

The Minimal Indicator was developed for an implementation in show bikes and racing bikes. It should be installed by professional well trained engineers only. Please check your local regulations regarding the traffic light rules in your country before of the use of the Minimal Indicator in your bike. Please be aware that we are not responsible for any hazards, damages or disadvantages due to the use of the Minimal Indicator. The electronicbox devices are registered under the number DE54933725 WEEE as B2C devices. We also declare that the Minimal Indicator is conform to the CE and ROHS regulations for the European market.

We tried to keep the functions of the Minimal Indicator and this manual as simple as possible. If you have any questions while the installation please don't hesitate to contact us at: info@elektronikbox.de

However, we wish you a lot of fun with your new Minimal Indicator and of course always a save trip!