

## Installation instruction Multi Flash S for the direction indicator switch

No time for manuals? No problem, this will only take a few minutes of your time to read it and the installation of your new Multi Flash S is done fast and easy :-)

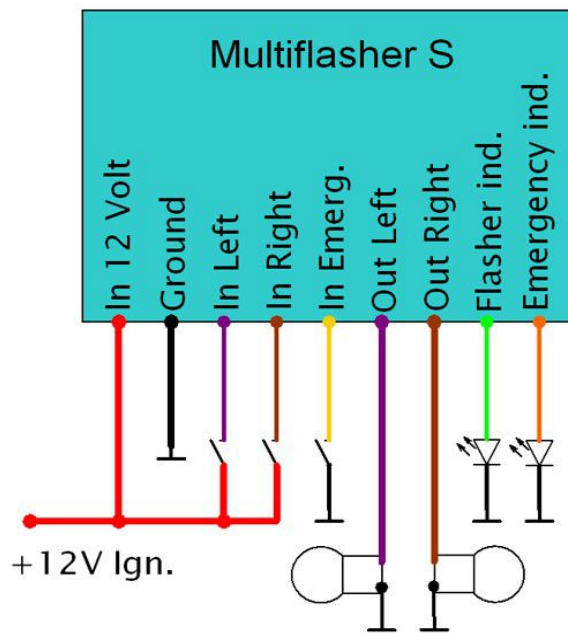

Color	Description
Violet (thin)	Switch input for the left flasher. Just connect it to your switch and wire the other button cable to plus 12 Volt ignition. A short tip to the indicator switch will activate the flasher for 3 times. The flasher is continuous activated if the switch is locked to the left side.
Brown (thin)	Switch input for the right flasher. Just connect it to your switch and wire the other button cable to plus 12 Volt ignition. A short tip to the indicator switch will activate the flasher for 3 times. The flasher is continuous activated if the switch is locked to the right side.
Green	Output for the flasher indicator led.
Yellow	Input for emergency switch. The emergency flasher function is activated when this input is switched to ground.
Orange	Output for emergency flasher led.
Red (thick)	+ 12 Power
Violet (thick)	Output left flasher
Brown	Output right flasher
Black	Ground

### Note:

**All unused program cables can be cut and should be insulated.** The outputs can control all kind of 12 Volt led flashers and "traditional" halogen bulbs up to 60 Watt per side. **Please note that the Multi Flasher S is made for installation in the handle bar or in the head light. An installation somewhere else at the bike with a short distance to the ignition result sometimes in "funny" unwanted functions of the Multi Flasher S due to electrostatic disturbances.**

The Multi Flasher S should be installed by professional well trained engineers. Please check your local regulations regarding the traffic light rules in your country before use the Multi Flasher S in your bike. Please be aware that we are not responsible for any hazards, damages or disadvantages due to the use of this device. We also declare that the Multi Flasher S is conform to the CE and ROHS regulations for the European market.

We tried to keep the functions of the Multi Flasher S and this manual as simple as possible. However, please don't hesitate to contact us at [info@elektronikbox.de](mailto:info@elektronikbox.de) if you have any questions during the installation.

**We wish you to have a lot of fun with your new Multi Flasher S in your bike and of course always Ride Safe!**